

**USH-C20-01**

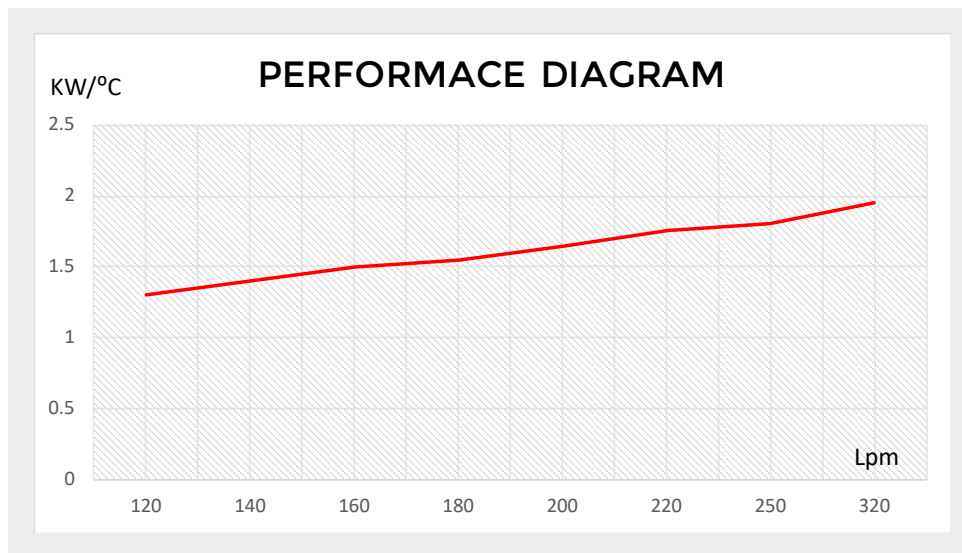
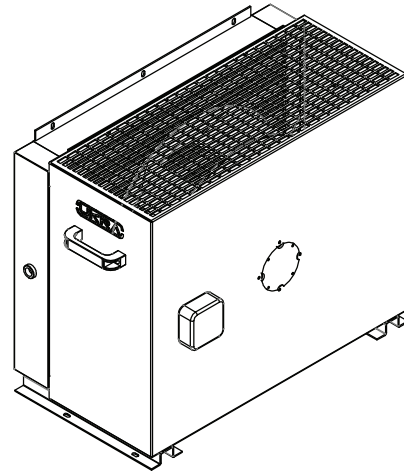
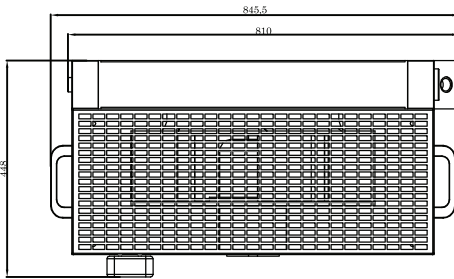
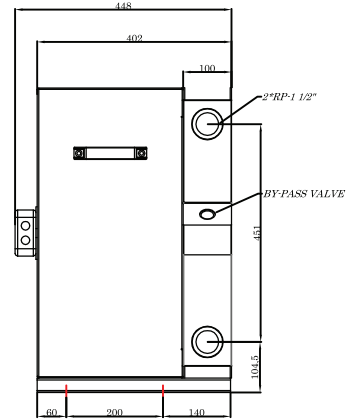
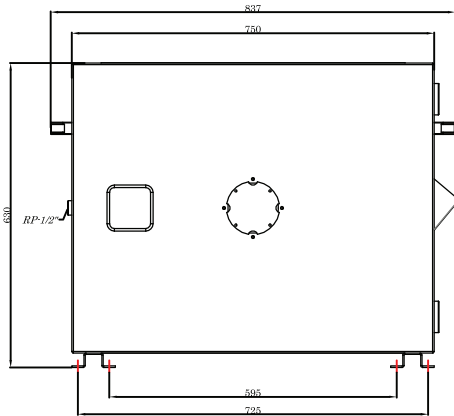

PRODUCT	OIL FLOW MAX	MAX COOLING CAPACITY	VOLTAGE	POWER	AIR	Ø FAN	FAN SPEED	ELECTRIC PROTECTION	NOISE LEVEL	CAPACITY	WEIGHT
	L/min	KW	V	W	m <sup>3</sup> /h	mm	RPM	IP	dB	L	Kg
USH - C20	180 - 300	65	230 AC	780	7,600	ø500	1,280	44	62	14	56