

**USH-C18-01**

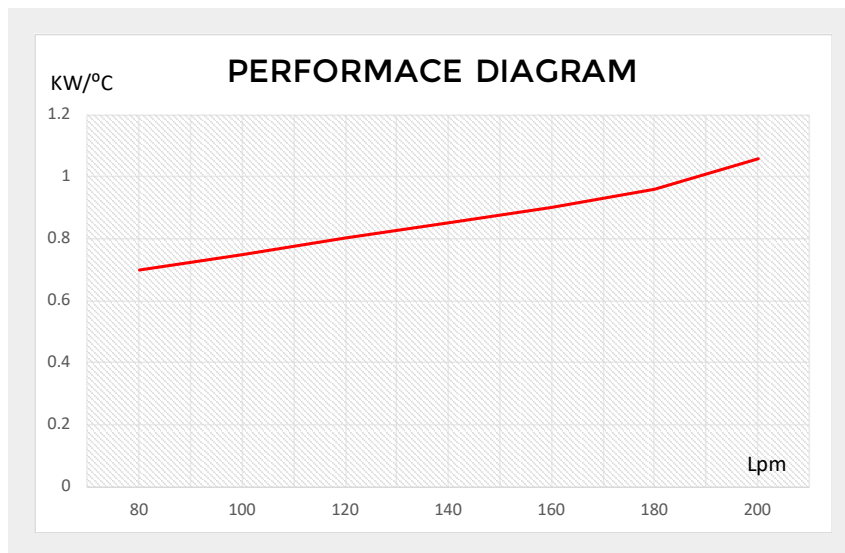
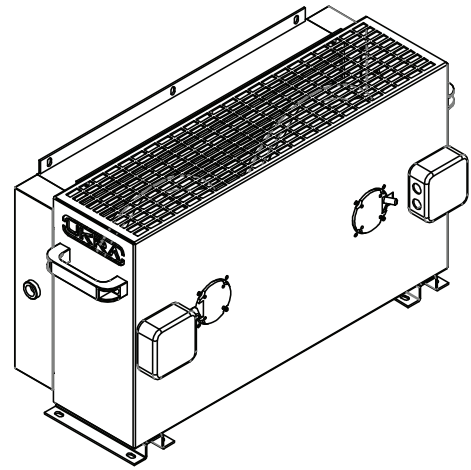
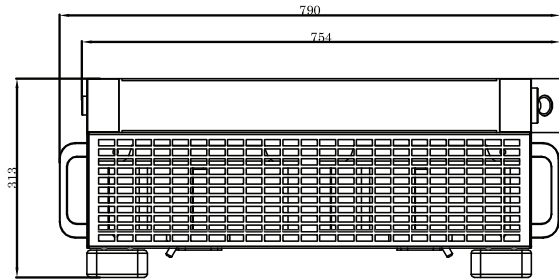
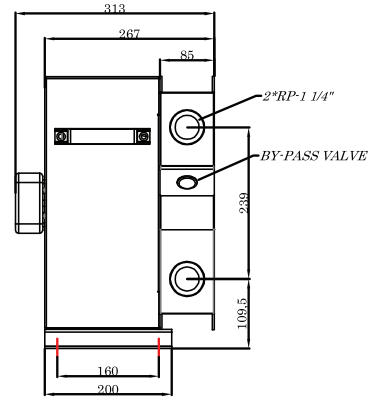
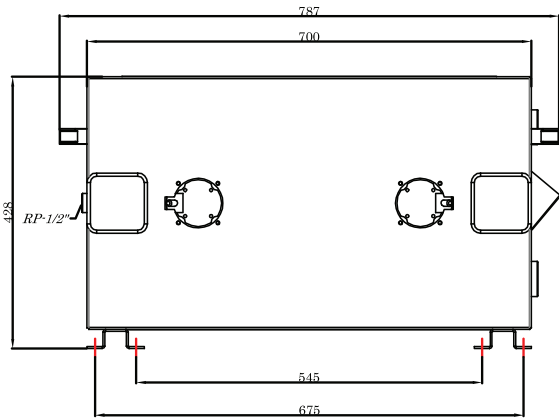

PRODUCT	OIL FLOW MAX	MAX COOLING CAPACITY	VOLTAGE	POWER	AIR	Ø FAN	FAN SPEED	ELECTRIC PROTECTION	NOISE LEVEL	CAPACITY	WEIGHT
	L/min	KW	V	W	m <sup>3</sup> /h	mm	RPM	IP	dB	L	Kg
USH - C18	120 - 200	45	230 AC	350	4,400	ø315x2	2,600	44	52	7.5	30