

UMB-A21-01/02

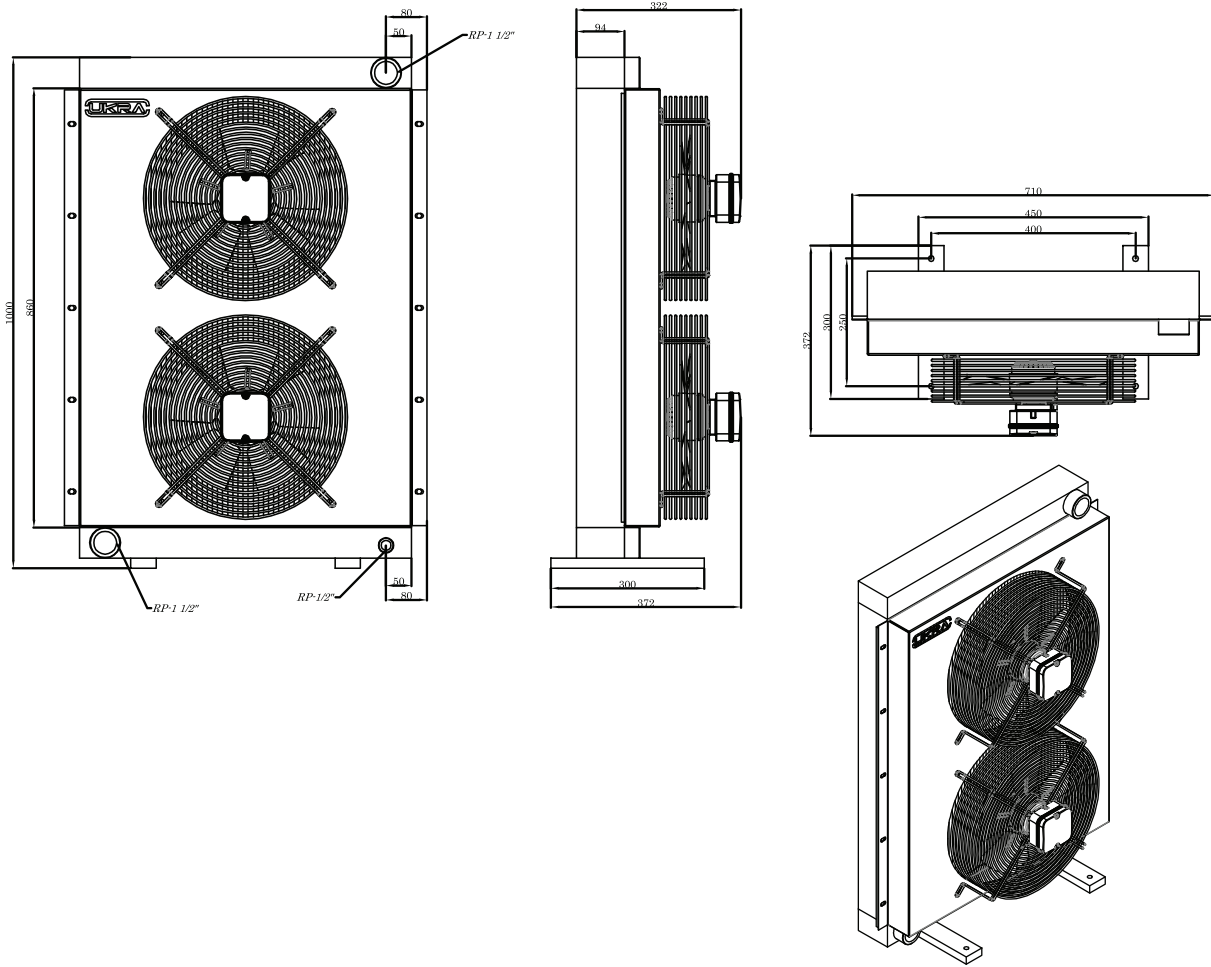

PRODUCT	OIL FLOW MIN-MAX	MAX COOLING CAPACITY	VOLTAGE	POWER	AIR	Ø FAN	FAN SPEED	ELECTRIC PROTECTION	CAPACITY	WEIGHT
	L/min	KW	V	W	m <sup>3</sup> /h	mm	RPM	IP	L	Kg
UMB - A21 - 01/02	250 - 500	75	230/400 AC	490	8,000	ø400 x 2	1,400	54	18	67

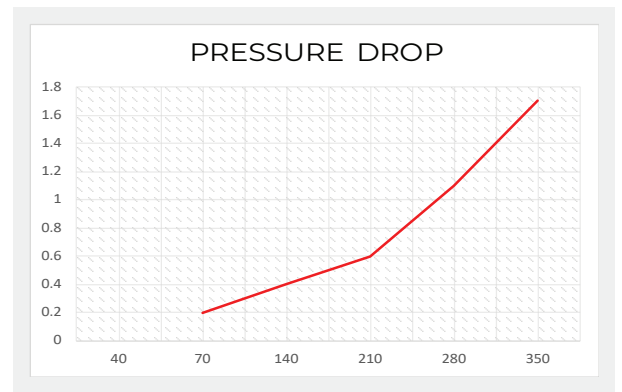
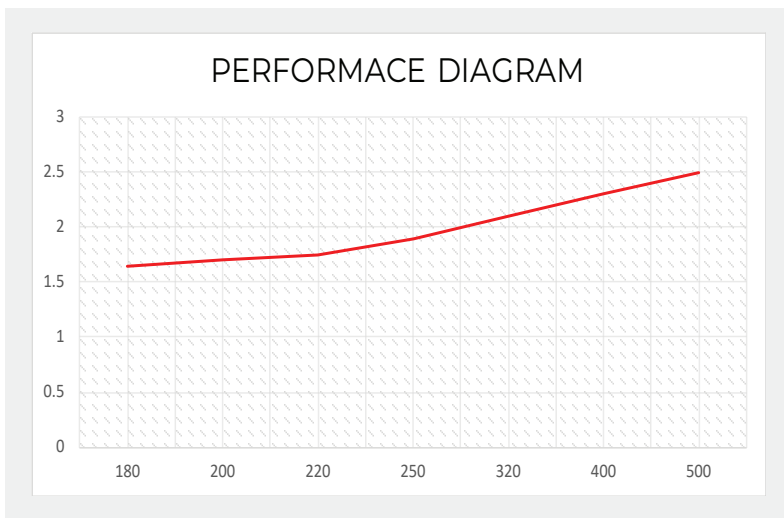

cSt	10	15	20	30	40	50	60	80	100	200	300
Pd	0.5	0.65	0.77	1	1.2	1.4	1.6	1.9	2.1	3.3	4.3